

PLAN VIEW

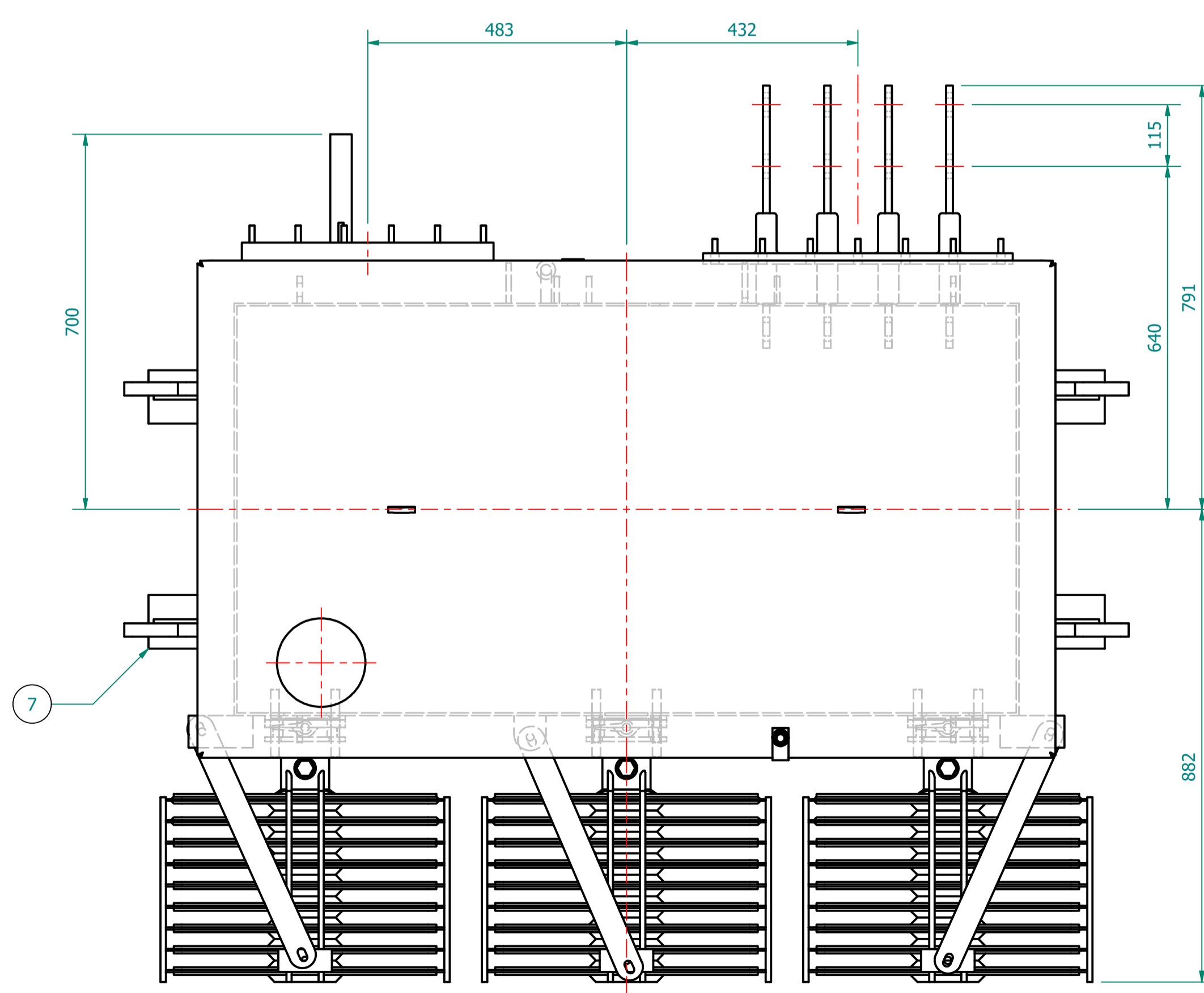
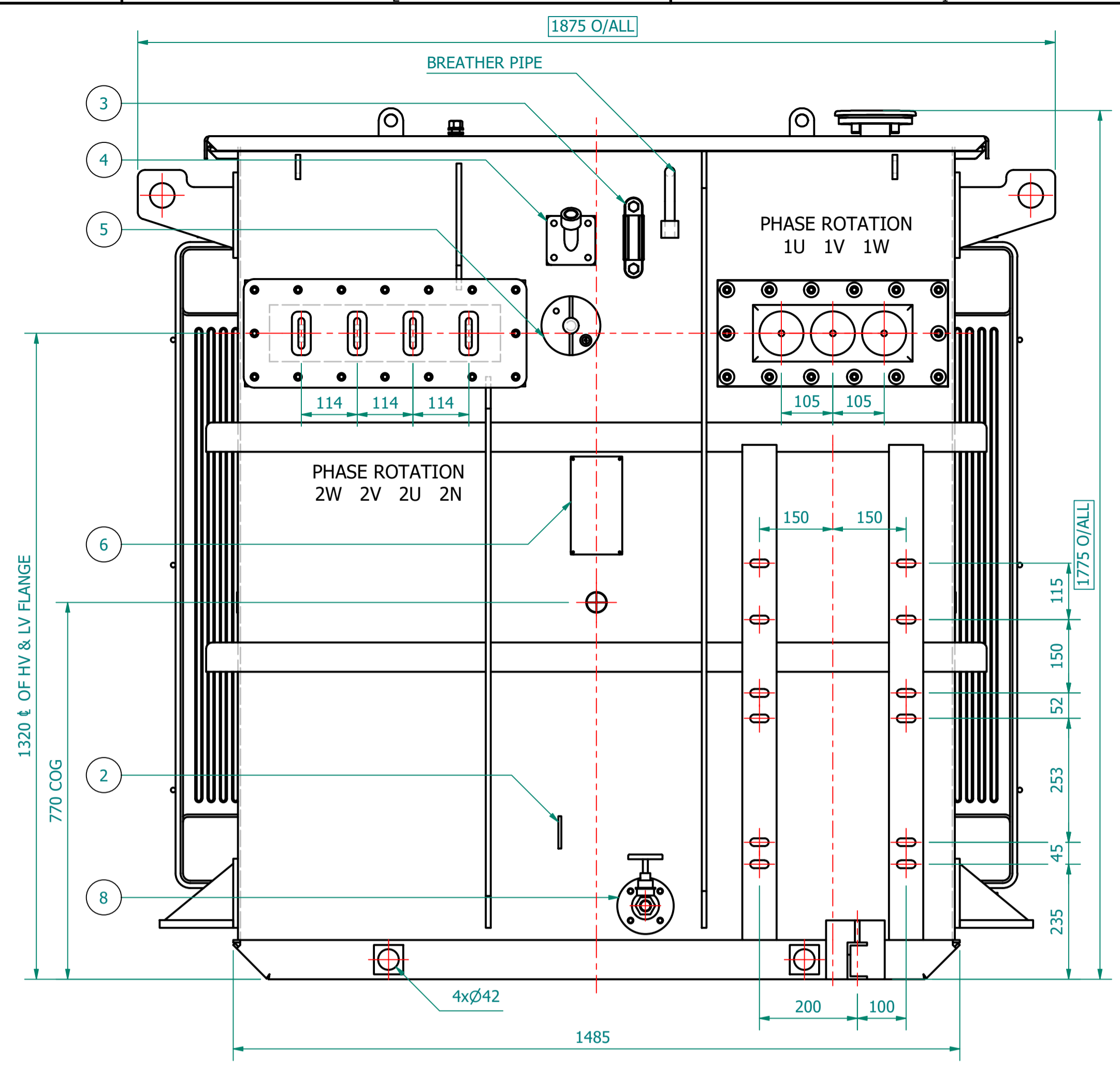
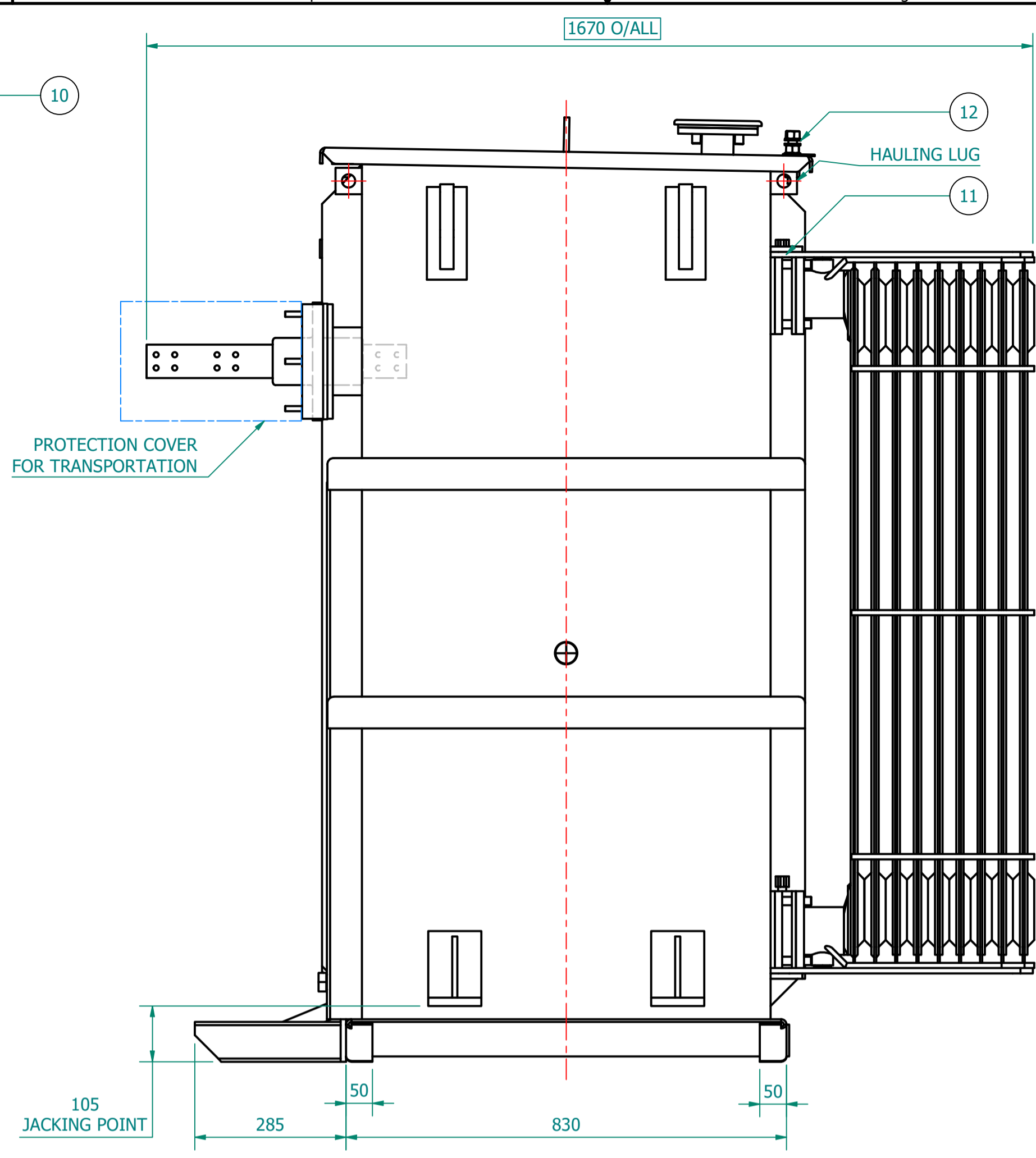

TRANSFORMER WEIGHT & VOLUME		
CORE AND WINDING	kg	2500
TANK AND FITTING	kg	1640
COOLING LIQUID VOLUME	L	1085
COOLING LIQUID WEIGHT	kg	890
TOTAL TX WEIGHT	kg	5030

2000kVA ELECTRICAL RATINGS					
No Load Voltage Ratio at Normal Tap	HV Tappings	Vector Group	Frequency	Full-Load Current at Normal Tap	
				HV Side	LV Side
11000 / 433V	+5 to -5.0% in 2.5% INCREMENTS	Dyn11	50Hz	104.97A	2666.75A
Design Impedance at Normal Tap	No Load Losses at rated Voltage & Frequency	Full Load Losses at rated Current & at 75°C Temp.	Temp. Rise above Ambient 40°C		
			in Oil by Therm.	in Wdg. by Res.	
6.0%	1305W	15000W	60°C	65°C	

ITEM	QTY	DESCRIPTION
14	3	DETACHABLE RADIATORS with AIR-RELEASE & DRAIN PLUG (520W x 1200C x 95 x 40P)
13	4	TRANSFORMER LIFTING LUGS
12	1	EARTHING STRIP ARRANGEMENT BETWEEN TANK AND TOP COVER
11	4	RADIATOR VALVE
10	1	TOP COVER with LIFTING LUGS (x2)
9	1	OIL FILLING PIPE WITH FLANGED COVER
8	1	DRAIN VALVE (25NB) with MALE PLUG
7	4	JACKING PADS
6	1	RATING & DIAGRAM PLATE (SS)
5	1	DE-ENERGIZE TAP CHANGER (5-Position & Padlockable)
4	1	THERMOMETER POCKET (3/4" BSP MALE THREAD)
3	1	OIL LEVEL GAUGE (with 15°) COLD OIL LEVEL MARK
2	1	EARTHING TERMINAL (FLAT TYPE suitable for M12 Bolt)
1	1	TRANSFORMER BASE (SKID TYPE) c/w HAULAGE HOLES

**ESSENTIAL LABELS**

ITEM 7 TAP CHANGER WARNING LABEL

ITEM 4 COLD COOLANT LEVEL

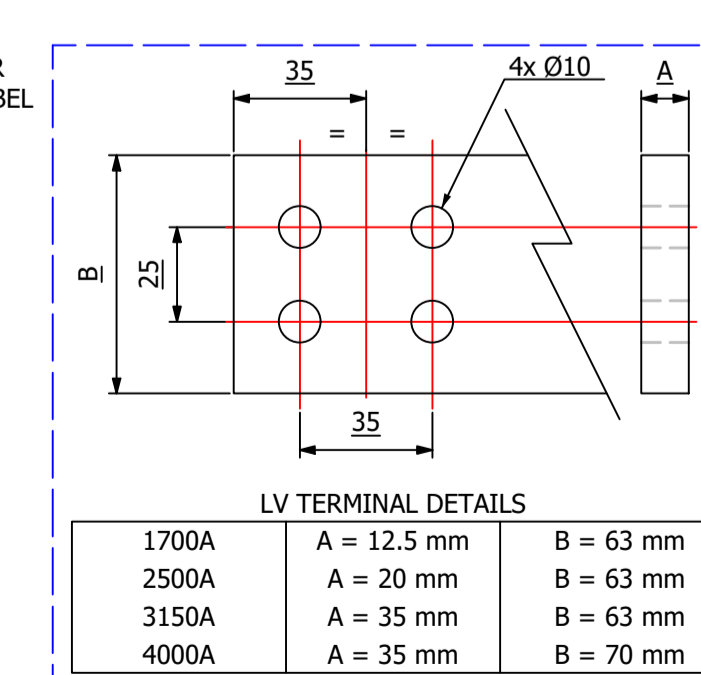

IF IN DOUBT - ASK. REMOVE ALL SHARP EDGES. DO NOT SCALE. DRAWING NOT TO SCALE

MANUFACTURED BY: **TOSHIBA TRANSFORMER**  
TOSHIBA TRANSMISSION & DISTRIBUTION SYSTEMS (INDIA) PVT. LTD.

REV	REV BY	VERIFIED	APPROVED	DESCRIPTION
01	M. STOTSJUK			MONOBLOCK CHANGED TO AN 8-WAY
00	M. STOTSJUK			ORIGINAL DESCRIPTION

REVISION DESCRIPTION	REV	PROJECT
NUMBER OF RADIATOR COOLING FINs REDUCED FROM 11 TO 9; OIL QTY & WEIGHTS ADJUSTED	02	

REV	DATE	PROJECT	CUSTOMER	S.O. NUMBER	P.O. NUMBER	W.O. NUMBER
02	14-OCT-2022					

DRAWING TITLE	
GENERAL ARRANGEMENT DRAWING FOR d2, 2000kVA 11000/433V, 50Hz, Dyn11, ONAN AL WOUND UNIT TYPE TRANSFORMER	

SUPPLIED BY: **Wilson Power Solutions Ltd.**  
Westland Square, Leeds, West Yorkshire LS11 5SS, United Kingdom  
Tel: +44 (0) 113 271 7588 Fax: +44 (0) 113 277 5124  
web: www.wilsonpowersolutions.co.uk email: info@wilsonpowersolutions.co.uk

web: www.wilsonpowersolutions.co.uk email: info@wilsonpowersolutions.co.uk

DRAWN BY: J. NOVO DATE: 14/10/2022 DRG NO: WPS-d2-UKPN-2000-AL-U001